

Utility sink VK60LB

Art. no. VK60LB-1
GTIN 7393069028348



Overall dimension in mm	655 x 505 x 250
Depth in mm	250
Bowl dim. in mm	600 x 450 x 250
Waste hole dim. in mm	52
Volume in L	47
Material	AISI 304
Material thickness in mm	1,2
Installation height in mm	900
Product load in N	1000
Net weight in kg	6.30
Pcs per pallet	16

Description

Wall hung utility sink in stainless steel. Supplied with stainless steel fixing brackets and ball valve.

Installation

Fix the stainless steel brackets to the sink and then the sink to the wall.

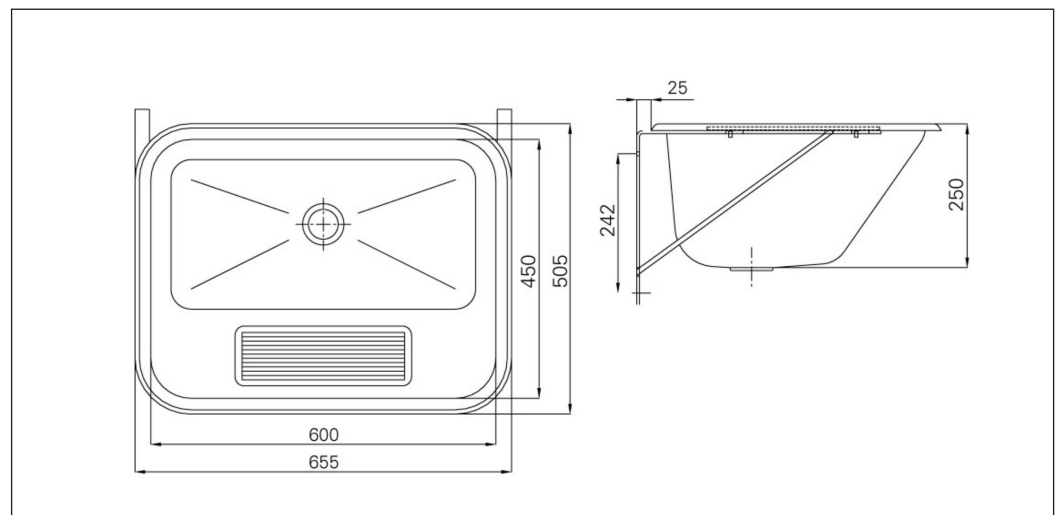

Installation VK60LB

ASSEMBLY:

Included in the box:

- * Wash basin
- * Valve with grated waste
- * Ball valve 1 1/4 "
- * Consoles
- * 4 discs
- * 4 nut M6

Make sure all parts are in place before assembly commences.

Valve, grated waste, rack, ball valve and brackets are fitted to the wash basin.

Attach the sink to the wall by using the holes in the brackets as a template for pre-drilling. Screws for wall mounting are not included, but make sure that screws are used that are correct in relation to the material and the construction in the wall the sink is to be fitted with.

SPARE PARTS:

Ball valve: 79019

Consoles: ZKONSVK60

Valve w / grated waste: 79136

Maintenance VK60LB

Maintenance of Intra products in stainless steel

Congratulations on your purchase of an Intra product that has been produced with care and to a high quality. Many of our products are supplied with a plastic film. This film protects the product during the transport and has to be removed before use.

To keep the original quality of your Intra product in AISI304 stainless steel, we recommend regular cleaning. Use washing up liquid and clean water to clean the product after use. Rinse carefully and dry. Don't forget to clean all loose parts, e.g. the drain grating.

Please have the following in mind

- Don't let water or other liquids dry on the product. In this way you avoid that a grey coating builds up on the steel.
- Stainless steel can stand hard treatment but sharp objects can easily scratch the surface. These scratches are more visible when the product is new. After a period of use these

marks will be smoothed out, without the product losing its lustre.

- Never use scouring powder or steel wool to clean the surface. Apart from the risk of scratches, there is also a risk that rust stains will attack the steel.
- Avoid Chlorine based solutions coming into contact with the stainless steel.
- Silver polish leaves spots that cannot be removed.
- Food-stuffs that contain acid or other substances must quickly be removed (e.g. juices, salt, mustard, mayonnaise).

Discoloration

More stubborn spots are often caused by impurities in the water or household substances. These can be removed with special polish agents for stainless steel. We recommend the use of Intra Shining Kit. Dull spots can become lustrous again if rubbed with chalk on a soft cloth.